

Product Summary

$V_{(BR)DSS}$	$R_{DS(on)MAX}$	I_D
-60V	28mΩ@10V	-50A

Feature

- High density cell design for ultra low Rdson
- Fully characterized avalanche voltage and current
- Good stability and uniformity with high E_{AS}
- Excellent package for good heat dissipation

Application

- Load switch

Package

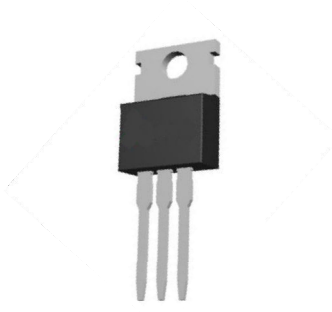

TO-220AB

Circuit diagram

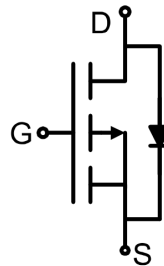

Marking

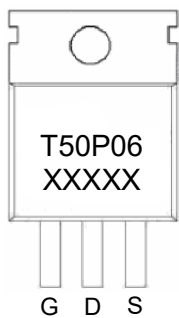

Absolute maximum ratings (Ta=25°C unless otherwise noted)

Parameter	Symbol	Value	Unit
Drain-Source Voltage	V _{DS}	-60	V
Gate-Source Voltage	V _{GS}	±20	V
Continuous Drain Current	I _D	-50	A
Pulsed Drain Current	I _{DM}	-150	A
Power Dissipation	P _D	95	W
Thermal Resistance, Junction-to-Case	R _{θJC}	1.31	°C/W
Single pulse avalanche energy	E _{AS}	722	mJ
Junction Temperature	T _J	150	°C
Storage Temperature	T _{STG}	-55 ~ +150	°C

Electrical characteristics (T_A=25 °C, unless otherwise noted)

Parameter	Symbol	Test Condition	Min.	Typ.	Max.	Unit
Static Characteristics						
Drain-source breakdown voltage	V _{(BR)DSS}	V _{GS} = 0V, I _D = -250μA	-60			V
Zero gate voltage drain current	I _{DSS}	V _{DS} = -60V, V _{GS} = 0V			-1	μA
Gate-body leakage current	I _{GSS}	V _{GS} = ±20V, V _{DS} = 0V			±100	nA
Gate threshold voltage	V _{GS(th)}	V _{DS} = V _{GS} , I _D = -250μA	-2.0		-3.5	V
Drain-source on-resistance ¹⁾	R _{DS(on)}	V _{GS} = -10V, I _D = -20A		23	28	mΩ
Forward transconductance ¹⁾	g _{FS}	V _{DS} = -10V, I _D = -20A		25		S
Dynamic characteristics²⁾						
Input Capacitance	C _{iss}	V _{DS} = -25V, V _{GS} = 0V, f = 1MHz		6460		pF
Output Capacitance	C _{oss}			719		
Reverse Transfer Capacitance	C _{rss}			535		
Total Gate Charge	Q _g	V _{DS} = -30V, V _{GS} = -10V, I _D = -20A		75		nC
Gate-Source Charge	Q _{gs}			16		
Gate-Drain Charge	Q _{gd}			19		
Turn-on delay time	t _{d(on)}	V _{DD} = -30V, V _{GS} = -10V, R _L = 1.5Ω, R _{GEN} = 3Ω		15		nS
Turn-on rise time	t _r			17		
Turn-off delay time	t _{d(off)}			40		
Turn-off fall time	t _f			45		
Source-Drain Diode characteristics						
Diode Forward Current ¹⁾	I _S				-20	A
Diode Forward voltage	V _{DS}	V _{GS} = 0V, I _S = -20A			-1.2	V
Reverse Recovery Time	t _{rr}	T _J = 25°C, I _F = -20A, di/dt = 100A/μs ¹⁾		50		nS
Reverse Recovery Charge	Q _{rr}			59		nC

Notes:

1) Pulse Test: Pulse Width < 300μs, Duty Cycle ≤2%.

2) Guaranteed by design, not subject to production testing.

Test Circuit

1) E_{AS} test Circuit

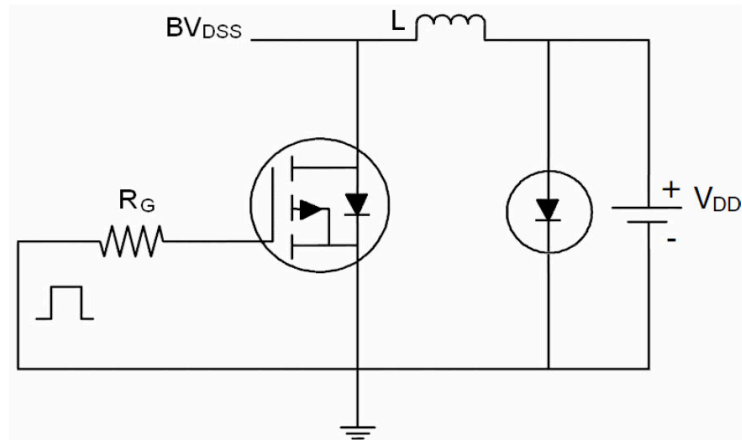

2) Gate charge test Circuit

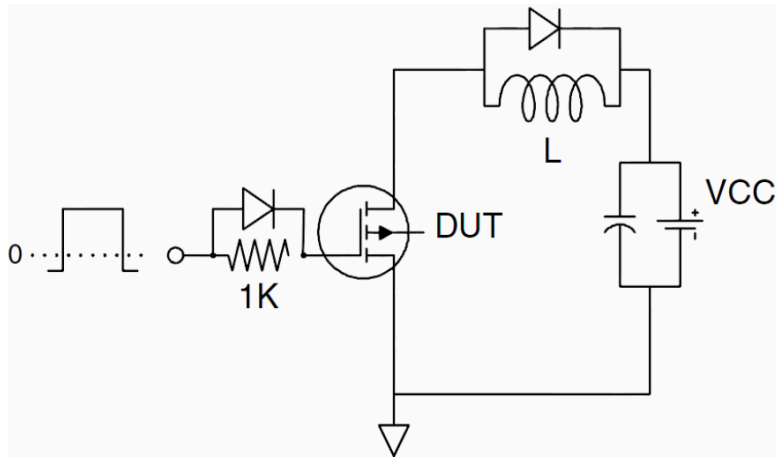

3) Switch Time Test Circuit

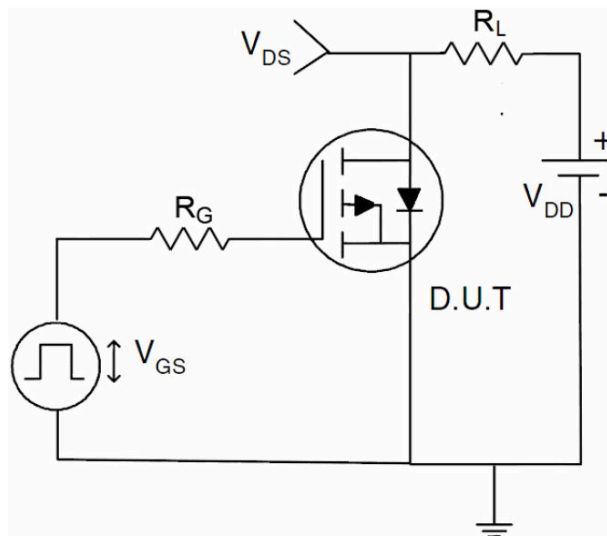

Typical Characteristics

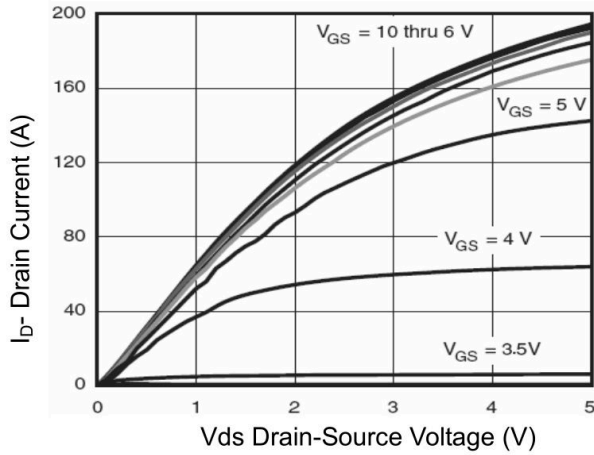

Figure 1 Output Characteristics

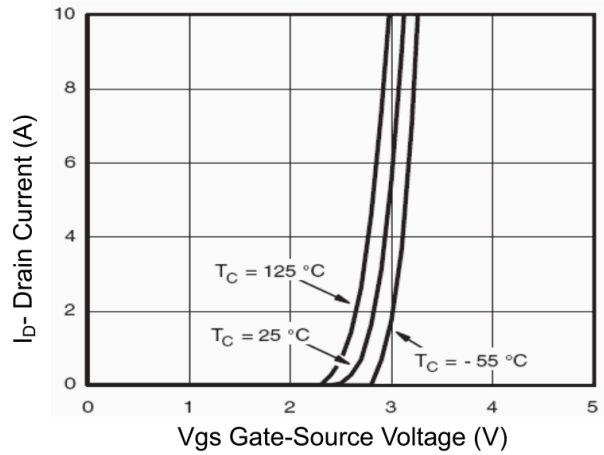

Figure 2 Transfer Characteristics

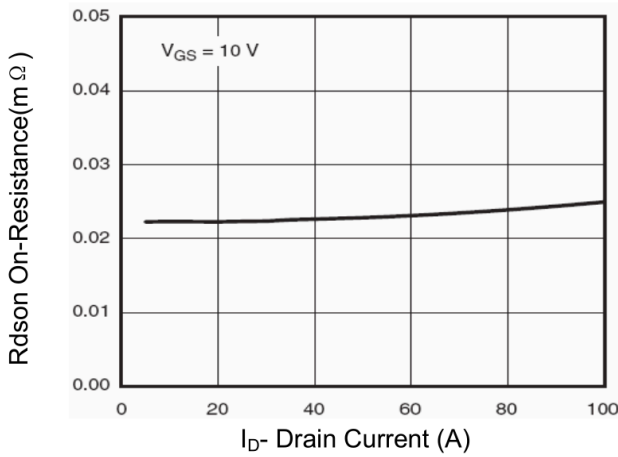

Figure 3 Rdson- Drain Current

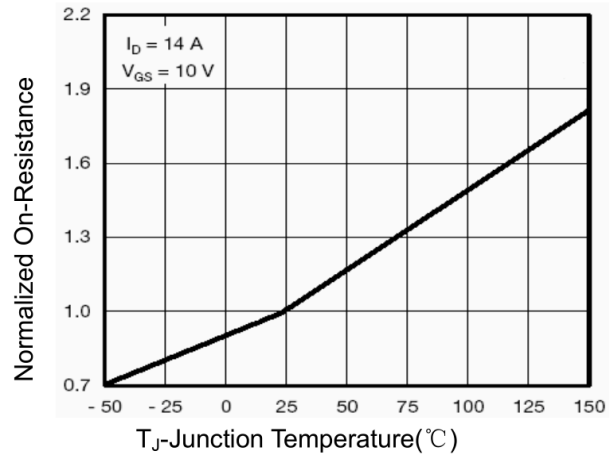

Figure 4 Rdson-Junction Temperature

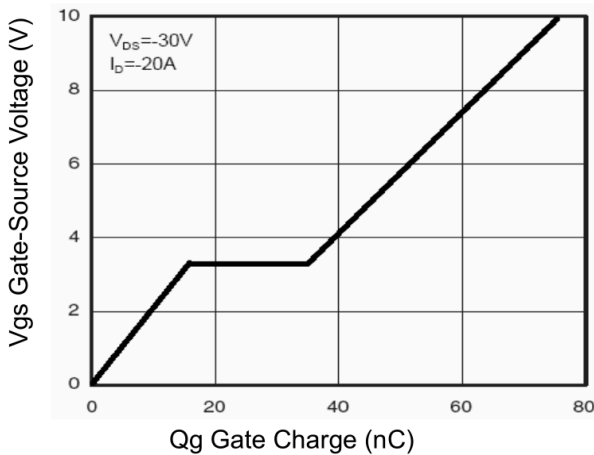

Figure 5 Gate Charge

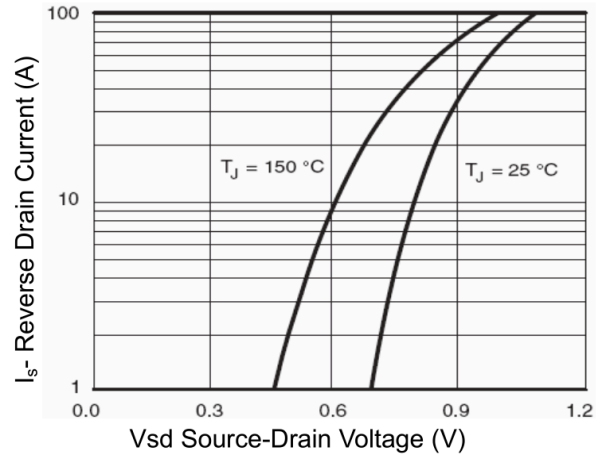

Figure 6 Source- Drain Diode Forward

Typical Characteristics

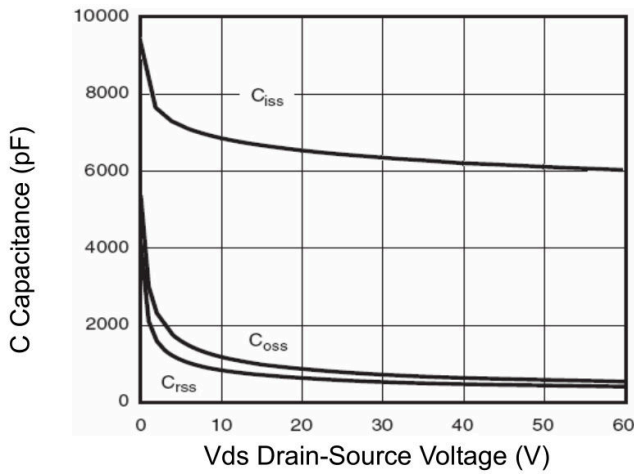

Figure 7 Capacitance vs Vds

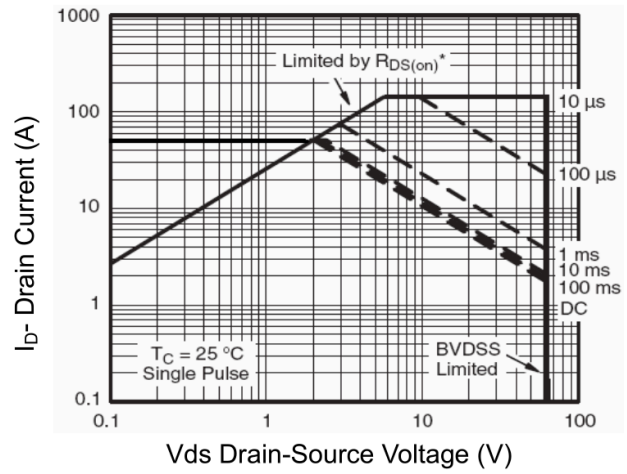

Figure 8 Safe Operation Area

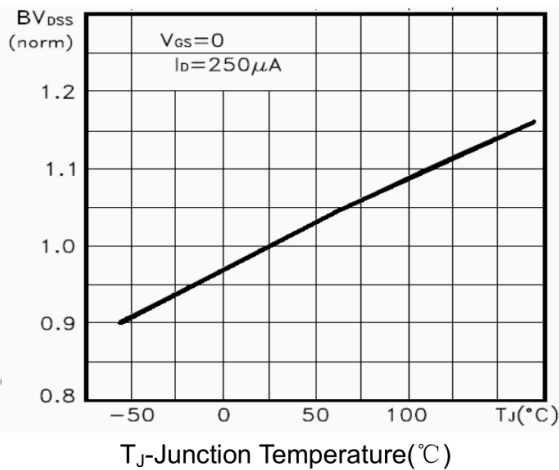

Figure 9 BV_{DSS} vs Junction Temperature

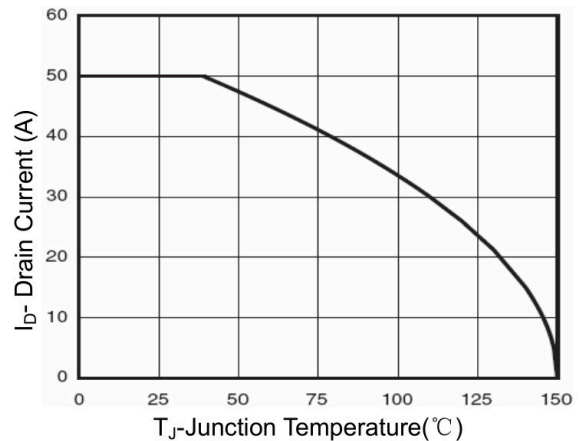

Figure 10 ID Current Derating vs Junction Temperature

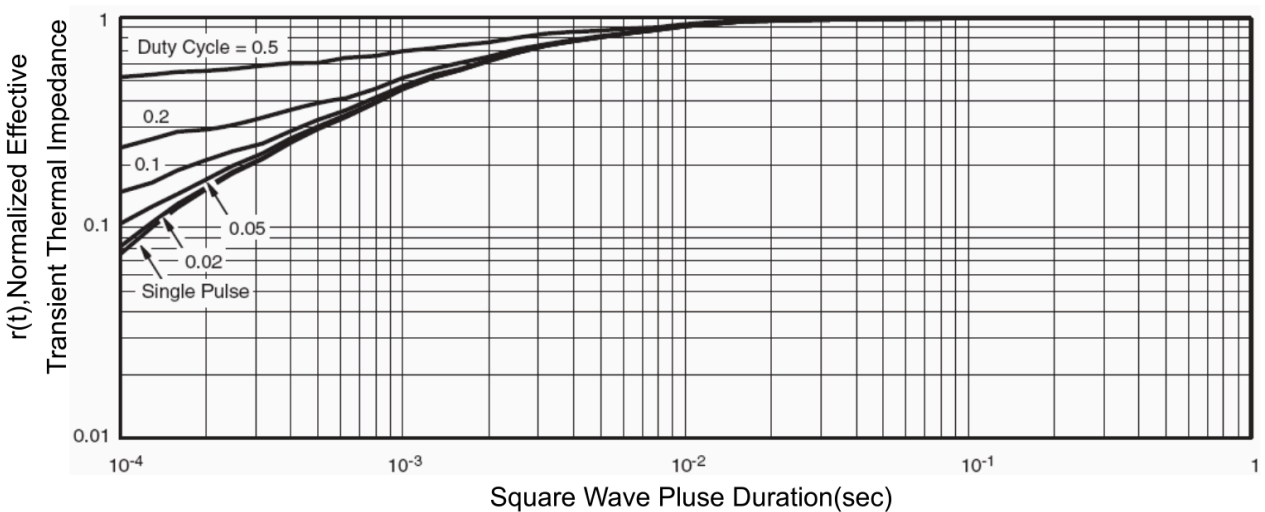
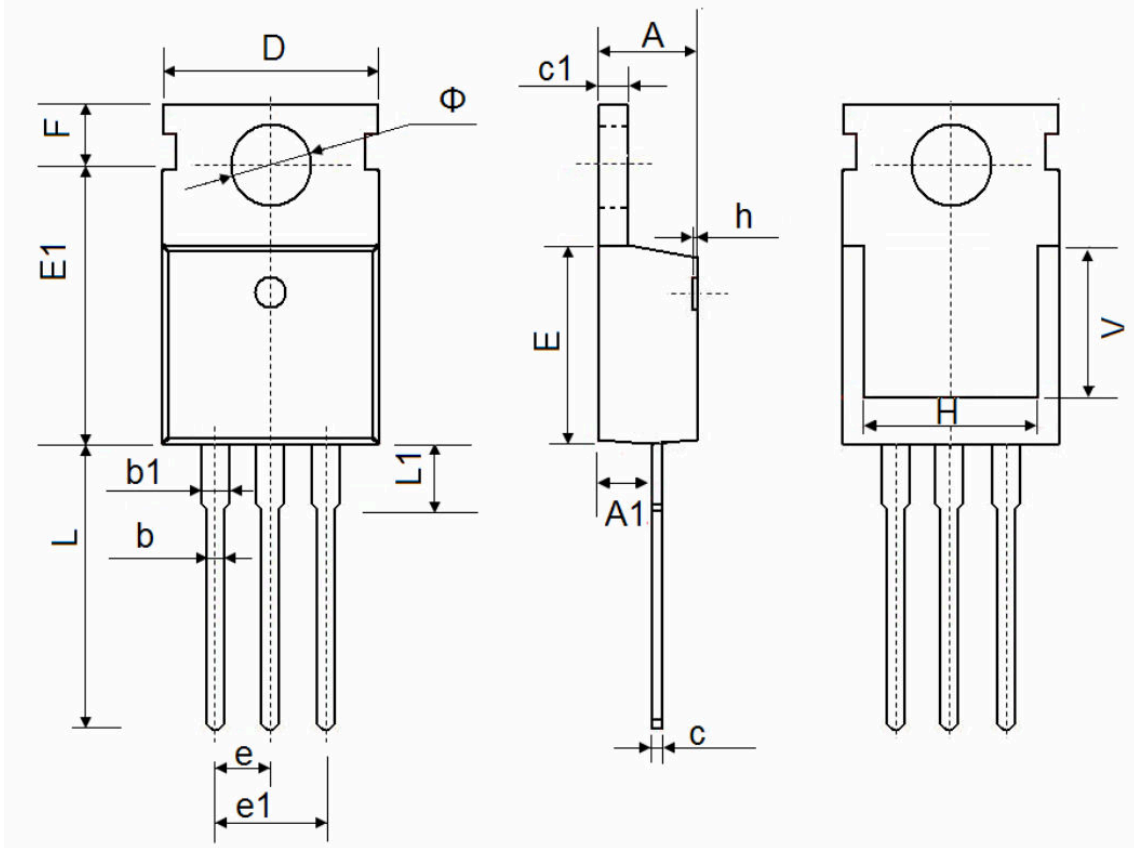

Figure 11 Normalized Maximum Transient Thermal Impedance

TO-220AB Package Information



Symbol	Dimensions In Millimeters		Dimensions In Inches	
	Min.	Max.	Min.	Max.
A	4.400	4.600	0.173	0.181
A1	2.250	2.550	0.089	0.100
b	0.710	0.910	0.028	0.036
b1	1.170	1.370	0.046	0.054
c	0.330	0.650	0.013	0.026
c1	1.200	1.400	0.047	0.055
D	9.910	10.250	0.390	0.404
E	8.9500	9.750	0.352	0.384
E1	12.650	12.950	0.498	0.510
e	2.540 TYP.		0.100 TYP.	
e1	4.980	5.180	0.196	0.204
F	2.650	2.950	0.104	0.116
H	7.900	8.100	0.311	0.319
h	0.000	0.300	0.000	0.012
L	12.900	13.400	0.508	0.528
L1	2.850	3.250	0.112	0.128
V	7.500 REF.		0.295 REF.	
Φ	3.400	3.800	0.134	0.150