

Features

- Uses CRM(CQ) advanced SkyMOS1 technology
- Extremely low on-resistance $R_{DS(on)}$
- Excellent $Q_g \times R_{DS(on)}$ product(FOM)
- Qualified according to JEDEC criteria

Applications

- Motor control and drive
- Battery management
- UPS (Uninterruptible Power Supplies)

Product Summary

V_{DS}	100V
$R_{DS(on)}$	2.6mΩ
I_D	180A

100% Avalanche Tested
100% DVDS Tested

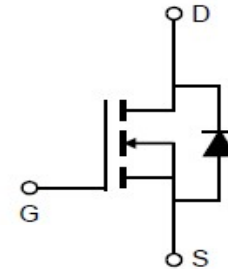
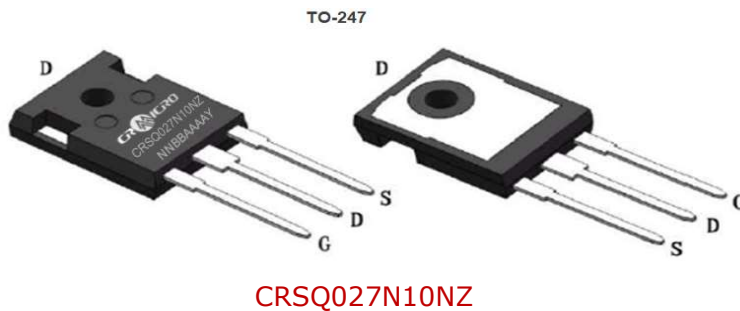
Package Marking and Ordering Information

Part #	Marking	Package	Packing	Reel Size	Tape Width	Qty
CRSQ027N10NZ	-	TO-247	Tube	N/A	N/A	30pcs

Absolute Maximum Ratings

Parameter	Symbol	Value	Unit
Drain-source voltage	V_{DS}	100	V
Continuous drain current $T_C = 25^\circ\text{C}$ (Silicon limit) $T_C = 25^\circ\text{C}$ (Package limit) $T_C = 100^\circ\text{C}$ (Silicon limit)	I_D	273 180 177	A
Pulsed drain current ($T_C = 25^\circ\text{C}$, t_p limited by T_{jmax})	$I_{D\ pulse}$	720	A
Avalanche energy, single pulse ($L=0.5\text{mH}$, $R_g=25\Omega$) ^[1]	E_{AS}	529	mJ
Gate-Source voltage	V_{GS}	± 20	V
Power dissipation ($T_C = 25^\circ\text{C}$)	P_{tot}	454	W
Operating junction and storage temperature	T_j, T_{stg}	-55...+150	$^\circ\text{C}$

Notes:1.EAS was tested at $T_j = 25^\circ\text{C}$, $I_D = 46\text{A}$.

Thermal Resistance

Parameter	Symbol	Max	Unit
Thermal resistance, junction – case.	R_{thJC}	0.28	°C/W
Thermal resistance, junction – ambient(min. footprint)	R_{thJA}	48	

Electrical Characteristic (at $T_j = 25\text{ }^\circ\text{C}$, unless otherwise specified)

Parameter	Symbol	Value			Unit	Test Condition
		min.	typ.	max.		

Static Characteristic

Drain-source breakdown voltage	BV_{DSS}	100	-	-	V	$V_{GS}=0V, I_D=250\mu A$
Gate threshold voltage	$V_{GS(th)}$	2.2	3	3.8	V	$V_{DS}=V_{GS}, I_D=250\mu A$
Zero gate voltage drain current	I_{DSS}	-	0.05	1	μA	$V_{DS}=100V, V_{GS}=0V$ $T_j=25^\circ C$ $T_j=125^\circ C$
Gate-source leakage current	I_{GSS}	-	± 10	± 100	nA	$V_{GS}=\pm 20V, V_{DS}=0V$
Drain-source on-state resistance	$R_{DS(on)}$	-	2.6	3.1	mΩ	$V_{GS}=10V, I_D=90A$
Transconductance	g_{fs}	-	197.2	-	S	$V_{DS}=5V, I_D=90A$

Dynamic Characteristic

Input Capacitance	C_{iss}	7570	11355	17033	pF	$V_{GS}=0V, V_{DS}=50V,$ $f=1MHz$
Output Capacitance	C_{oss}	964	1446	2169		
Reverse Transfer Capacitance	C_{rss}	36	54	81		
Gate Total Charge	Q_G	112.7	169	253.5	nC	$V_{GS}=10V, V_{DS}=50V,$ $I_D=90A, f=1MHz$
Gate-Source charge	Q_{gs}	44.7	67	100.5		
Gate-Drain charge	Q_{gd}	20	30	45		
Turn-on delay time	$t_{d(on)}$	23.3	35	52.5	ns	$V_{GS}=10V, V_{DD}=50V,$ $R_{G_ext}=3.0\Omega$
Rise time	t_r	74	111	166.5		
Turn-off delay time	$t_{d(off)}$	56	84	126		
Fall time	t_f	74.7	112	168		
Gate resistance	R_G	-	1.8	5.5	Ω	$V_{GS}=0V, V_{DS}=0V,$ $f=1MHz$

Body Diode Characteristic

Parameter	Symbol	Value			Unit	Test Condition
		min.	typ.	max.		
Body Diode Forward Voltage	V_{SD}	-	0.9	1.4	V	$V_{GS}=0V, I_{SD}=90A$
Body Diode Reverse Recovery Time	t_{rr}	50.5	101	202	ns	$I_F=90A, dI/dt=100A/\mu s$
Body Diode Reverse Recovery Charge	Q_{rr}	169	338	676	nC	

Typical Performance Characteristics

Fig 1: Output Characteristics

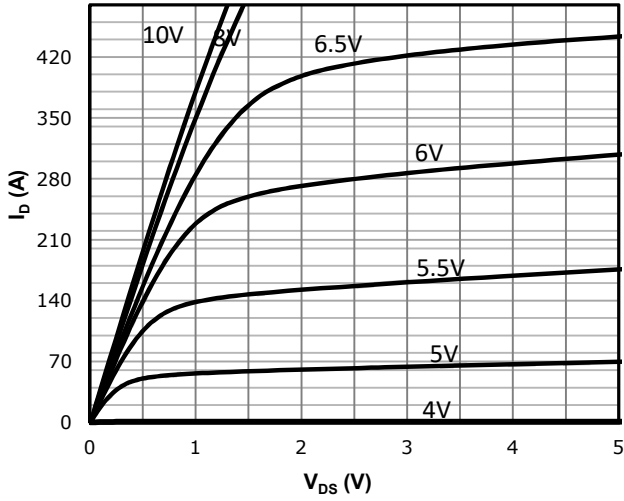
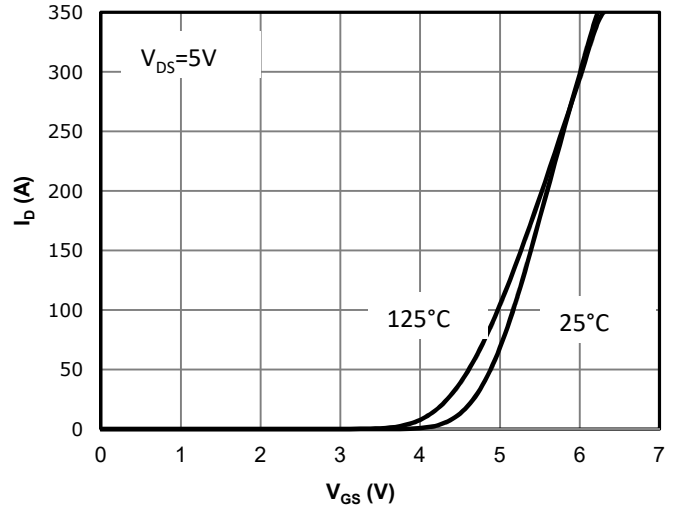

Fig 2: Transfer Characteristics



3: $R_{DS(on)}$ vs Drain Current and Gate Voltage

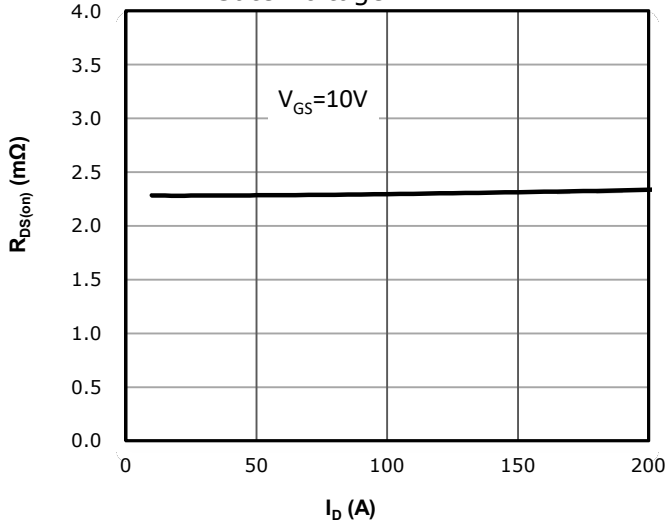

Fig 4: $R_{DS(on)}$ vs Gate Voltage

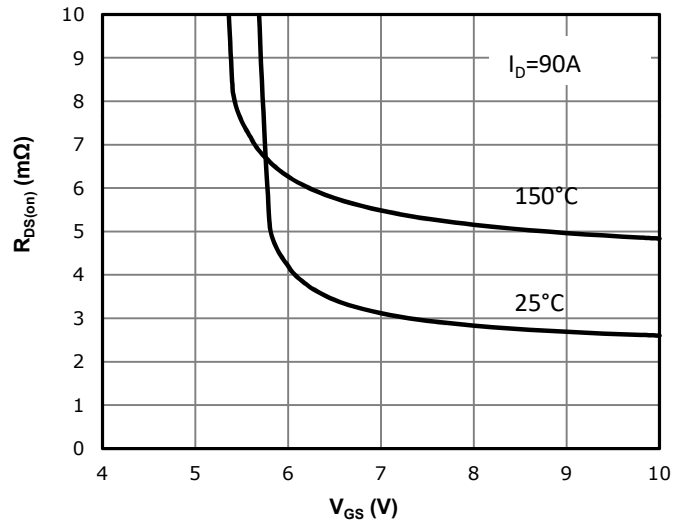

Fig 5: $R_{DS(on)}$ vs. Temperature

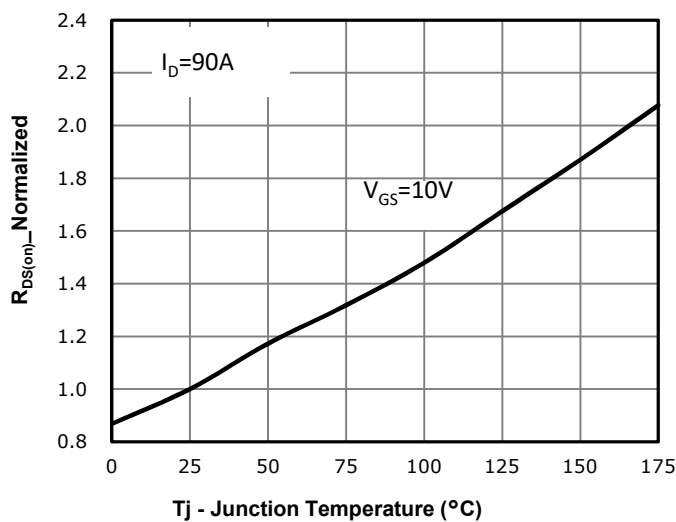

Fig 6: Capacitance Characteristics

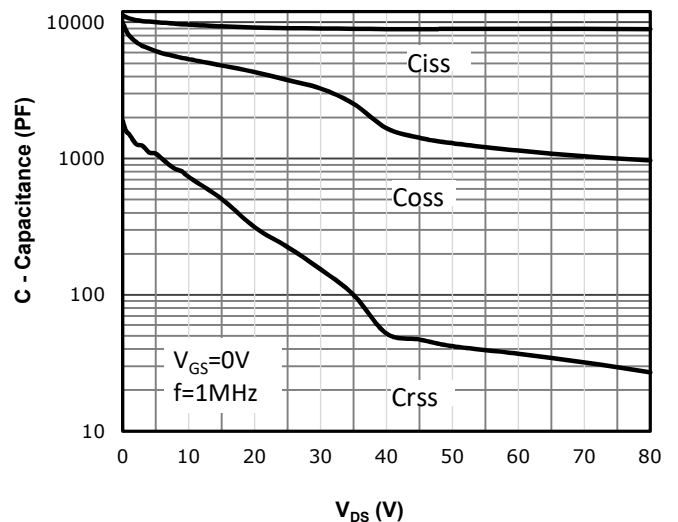

Fig 7: Gate Charge Characteristics

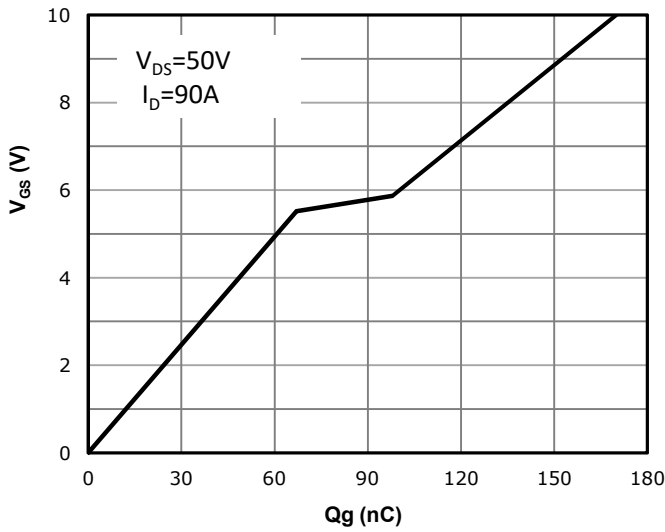

Fig 8: Body-diode Forward Characteristics

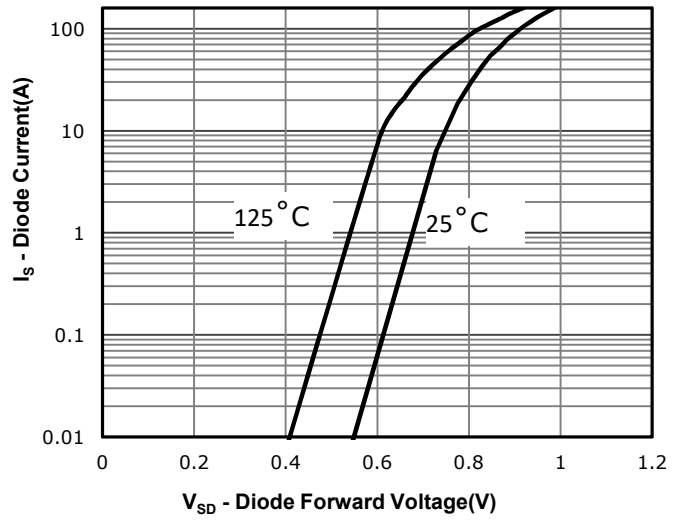

Fig 9: Power Dissipation

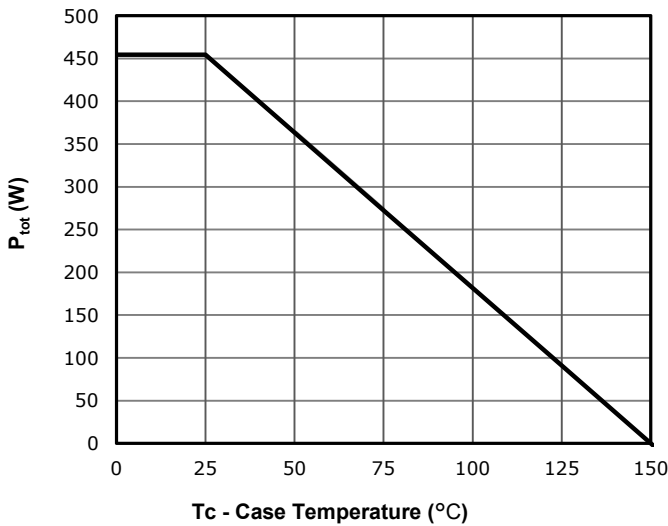

Fig 10: Drain Current Derating

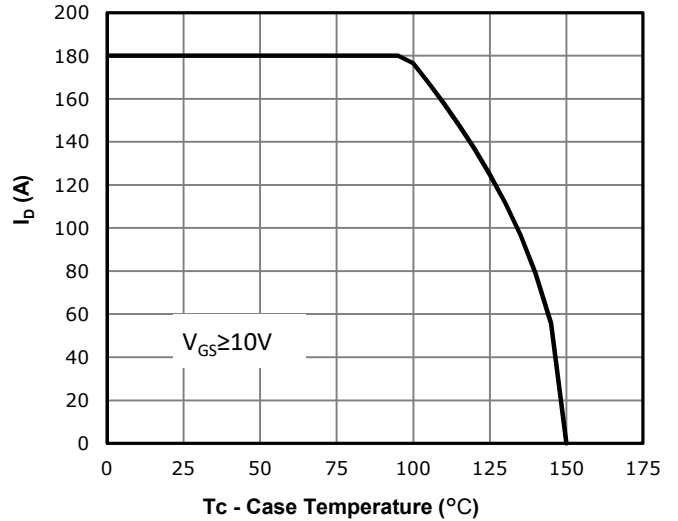

Fig 11: Safe Operating Area

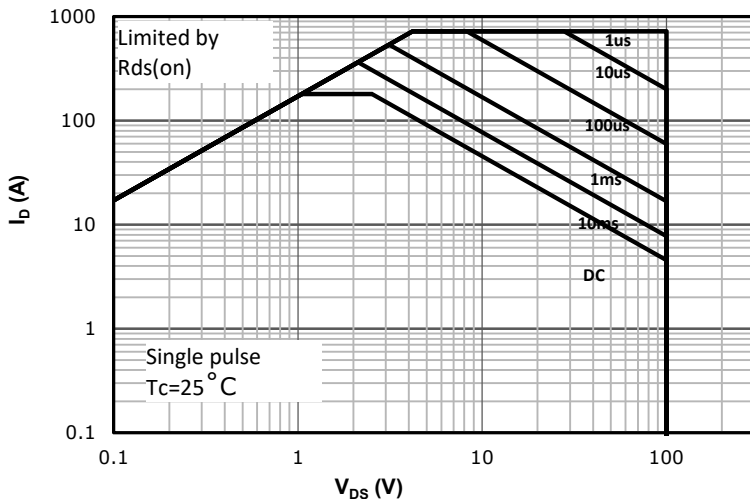
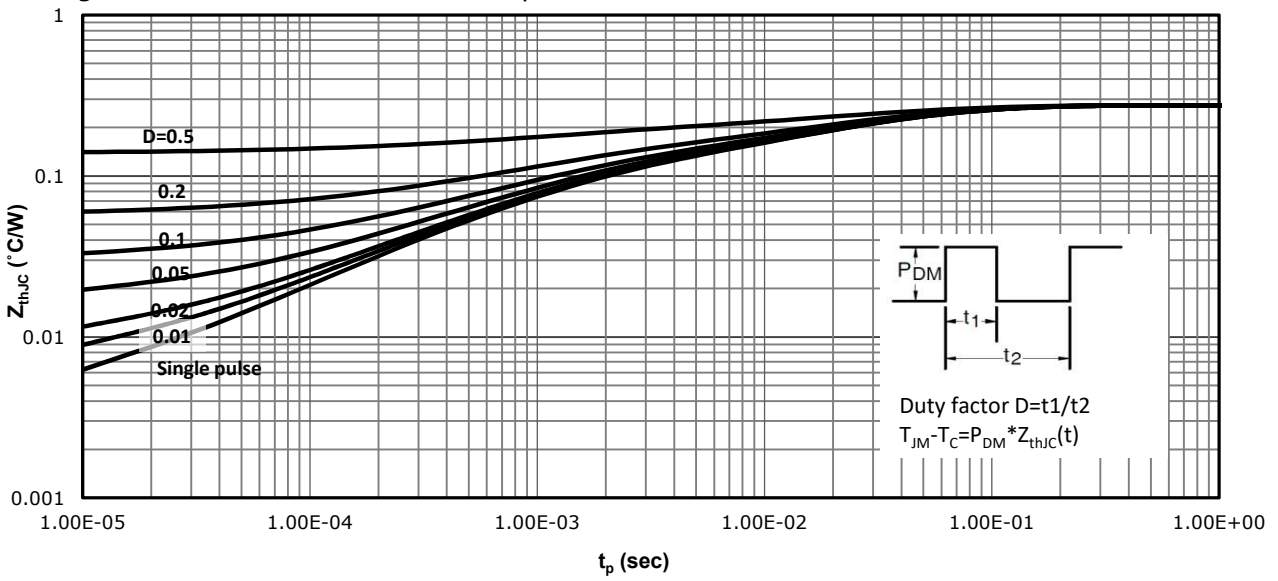
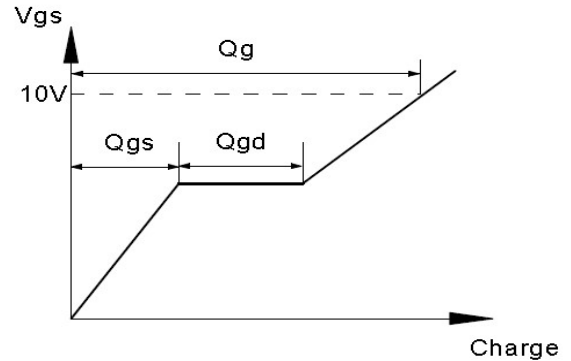
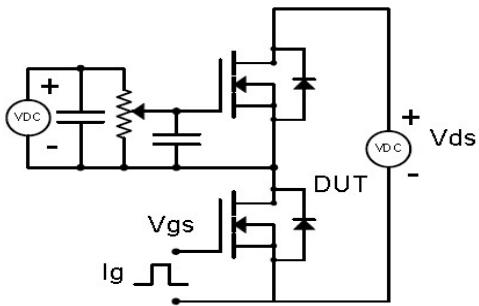

Fig 12: Max. Transient Thermal Impedance



Test Circuit & Waveform

Gate Charge Test Circuit & Waveform



Resistive Switching Test Circuit & Waveforms

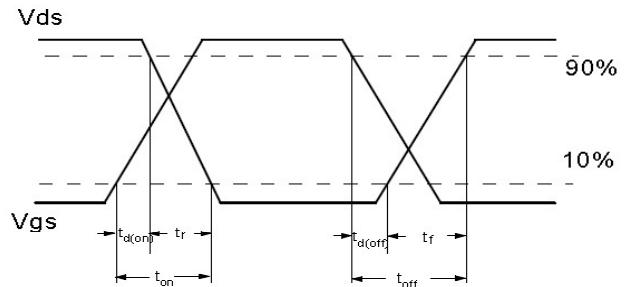
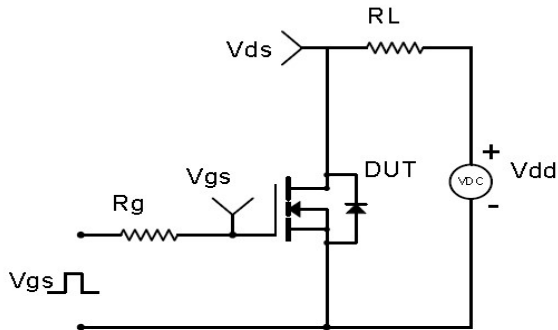

Unclamped Inductive Switching (UIS) Test Circuit & Waveforms

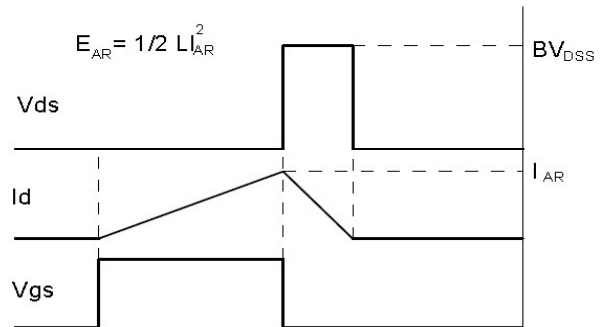
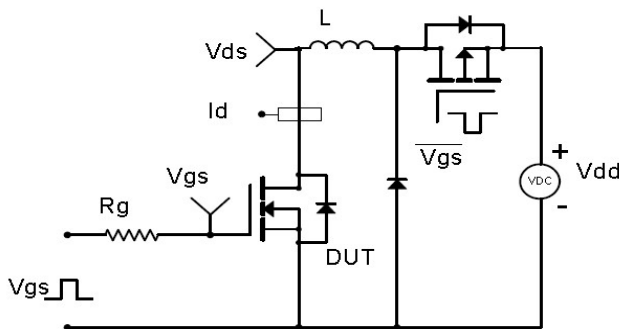

Diode Recovery Test Circuit & Waveforms

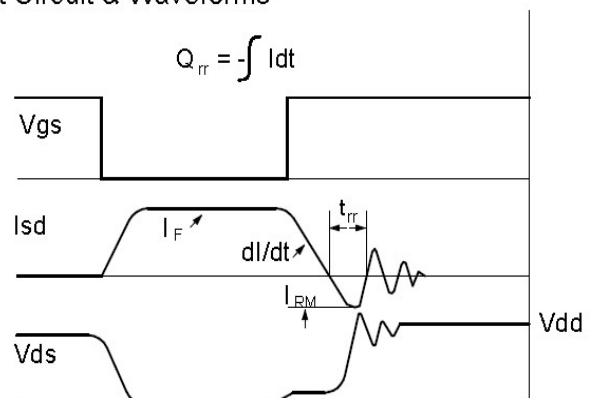
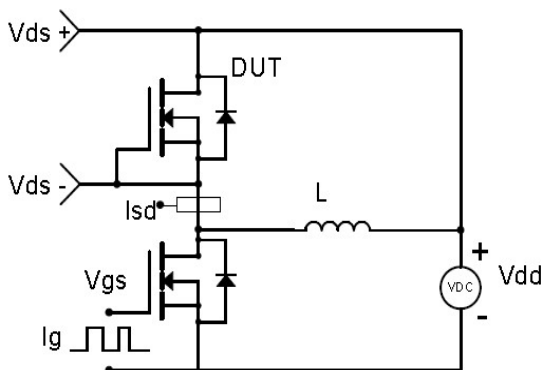

Package Outline: TO-247

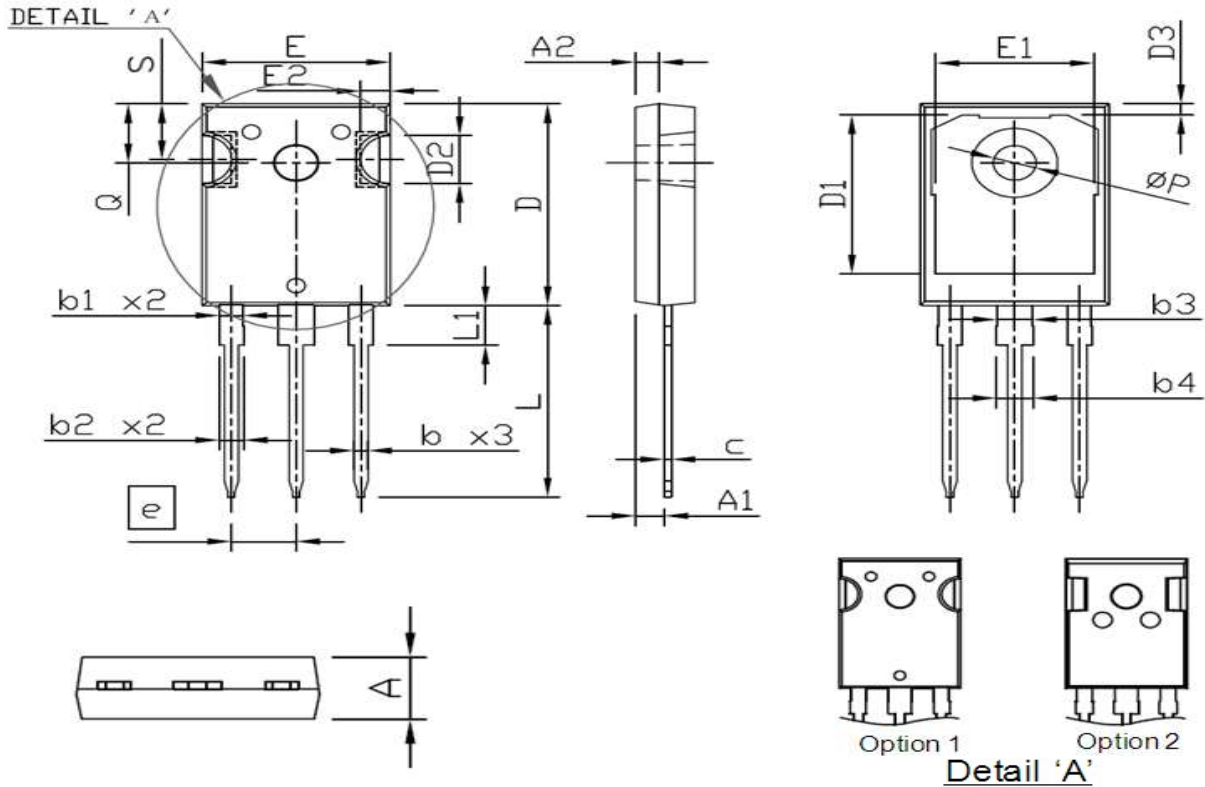

Symbol	Dimensions In Millimeters		Dimensions In Inches	
	Min.	Max.	Min.	Max.
A	4.85	5.15	0.191	0.203
A1	2.27	2.54	0.089	0.100
A2	1.90	2.10	0.075	0.083
b	1.07	1.33	0.042	0.052
b1	1.90	2.16	0.075	0.085
b2	2.00	2.21	0.079	0.087
b3	2.87	3.13	0.113	0.123
b4	2.87	3.20	0.113	0.126
c	0.55	0.68	0.022	0.027
D	20.80	21.10	0.819	0.831
D1	16.25	17.65	0.640	0.695
D2	3.68	5.10	0.145	0.201
D3	0.95	1.35	0.037	0.053
e	5.44 BSC.		0.214 BSC.	
E	15.70	16.13	0.618	0.635
E1	13.03	14.15	0.513	0.557
E2	2.20	2.60	0.087	0.102
L	19.72	20.32	0.776	0.800
L1	4.00	4.47	0.157	0.176
Q	6.04	6.30	0.238	0.248
P	3.50	3.70	0.138	0.146
S	5.49	6.00	0.216	0.236

Revision History

Revision	Date	Major changes
1.0	2022/12/28	Release of formal version.

Disclaimer

Unless otherwise specified in the datasheet, the product is designed and qualified as a standard commercial product and is not intended for use in applications that require extraordinary levels of quality and reliability, such as automotive, aviation/aerospace and life-support devices or systems.

Any and all semiconductor products have certain probability to fail or malfunction, which may result in personal injury, death or property damage. Customer are solely responsible for providing adequate safe measures when design their systems.

CRM(CQ) reserves the right to improve product design, function and reliability without notice.