

Features

●

V_{DSS}	$R_{DS(ON)}$ @ 10V (Typ)	I_D
80V	7 mΩ	88A

- Avalanche Rated
- Reliable and Rugged
- Advanced trench process technology
- High Density Cell Design For Ultra Low On-Resistance
- RoHS Compliant

Applications

- Synchronous Rectification
- Power Management in Inverter System

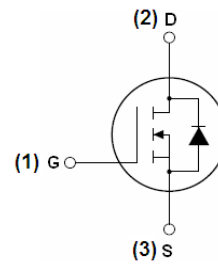

Schematic diagram

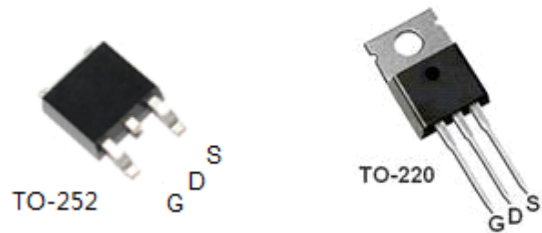

Ordering Information

Part Number	Marking	Case	Packaging
8070	8070	TO-252	2500pcs/Tube
8070	8070	TO-220	50pcs/Tube

Switching Time Test Circuit and Waveforms

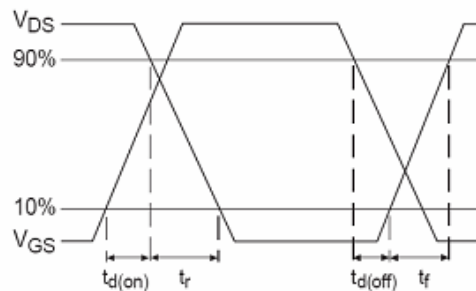
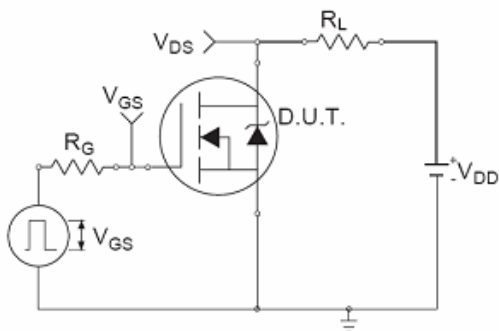

Absolute Maximum Ratings ($T_A=25^{\circ}\text{C}$ unless otherwise noted)

Symbol	Parameter	Typical	Unit	
V_{DSS}	Drain-Source Voltage	80	V	
V_{GSS}	Gate -Source Voltage	± 25	V	
I_D	Continuous Drain Current	$T_C=100^{\circ}\text{C}$	50	A
			88	A
I_{DP}	300us Pulsed Drain Current Tested	280	A	
I_S	Diode Continuous Forward Current			70
EAS	Single Pulse Avalanche Energy	550	mJ	
T_J	Operating Junction Temperature	175	$^{\circ}\text{C}$	
T_{STG}	Storage Temperature Range	-55 ~ 175	$^{\circ}\text{C}$	

Electrical Characteristics ($T_A=25^{\circ}\text{C}$ Unless otherwise noted)

Symbol	Parameter	Test Conditions	Min.	Typ	Max.	Unit
Static Characteristics						
BV_{DSS}	Drain-Source Breakdown Voltage	$V_{GS}=0V, I_D=250\mu A$	80			V
$\Delta BV_{DSS}/\Delta T_J$	Breakdown Voltage Temp. Coe			0.073		
I_{DSS}	Zero Gate Voltage Drain Current	$V_{DS}=-24V, V_{GS}=0V$ $T_J=85^{\circ}\text{C}$			1	uA
					30	
$V_{GS(th)}$	Gate Threshold Voltage	$V_{DS}=V_{GS}, I_D=-250\mu A$	2	3	4	V
I_{GSS}	Gate Leakage Current	$V_{GS}=\pm 25V, V_{DS}=0V$			± 100	nA
$R_{DS(on)}^1$	Drain-Source On-Resistance	$V_{GS}=10V, I_D=40A$		7	8.2	m Ω
Diode Characteristics						
V_{SD}^1	Diode Forward Voltage	$I_{SD}=20A, V_{GS}=0V$		0.8	1.3	V
t_{rr}	Reverse Recovery Time	$I_{SD}=40A,$		50		ns
Q_{rr}	Reverse Recovery Charge	$dI_{SD}/dt=100A/\mu s$		90		nC
Dynamic Characteristics²						
R_G	Gate Resistance	$V_{GS}=0V, V_{DS}=0V,$ Frequency=1MHz		1.3		Ω
C_{iss}	Input Capacitance	$V_{GS}=0V, V_{DS}=30V$ Frequency=1MHz		3000	4200	pF
C_{oss}	Output Capacitance			350		
C_{riss}	Reverse Transfer Capacitance			250		
$t_{d(on)}$	Turn-On Delay Time	$V_{DD}=30V, R_L=30\Omega$ $I_D=1A, V_{GEN}=10V$ $R_G=6\Omega$		22	40	ns
t_r	Turn-On Rise Time			14	25	
$t_{d(off)}$	Turn-Off Delay Time			58	104	
t_f	Turn-Off Fall Time			25	45	
Gate Charge Characteristics²						
Q_g	Total Gate Charge	$V_{DS}=40V, V_{GS}=10V$ $I_D=40A$		77	108	nC
Q_{gs}	Gate-Source Charge			22		
Q_{gd}	Gate-Drain Charge			23		

Note: 1: Pulse test ; pulse width $\leq 300\text{ns}$, duty cycle $\leq 2\%$.

2: Guaranteed by design, not subject to production testing.

Typical Characteristics

Power Dissipation

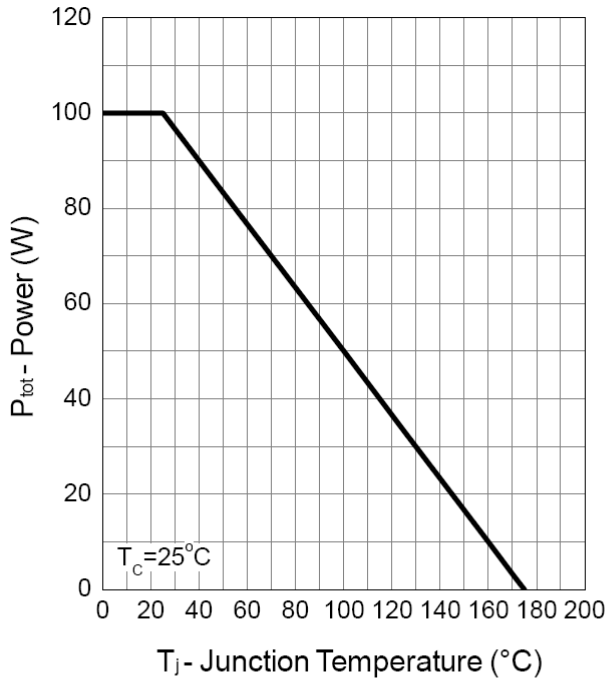

Drain Current

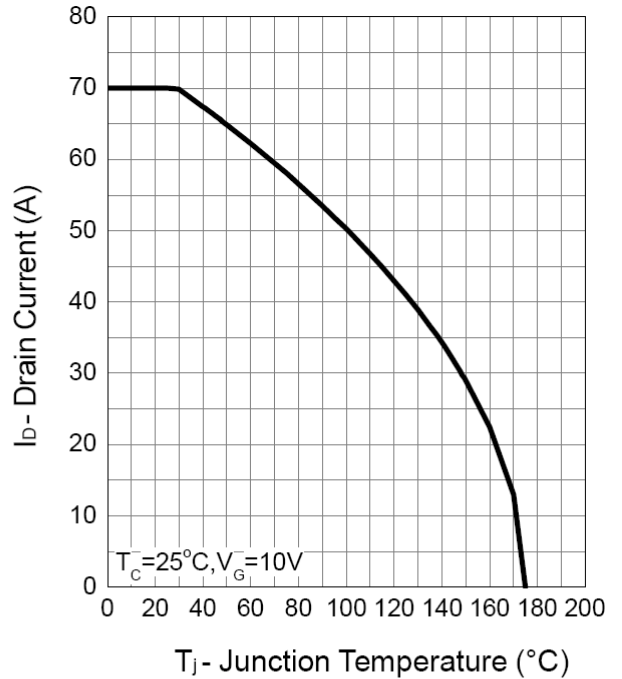

Safe Operation Area

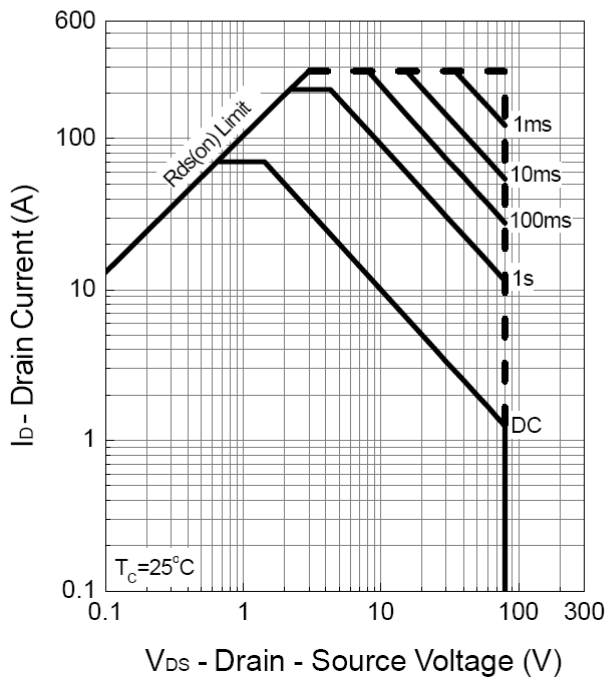

Thermal Transient Impedance

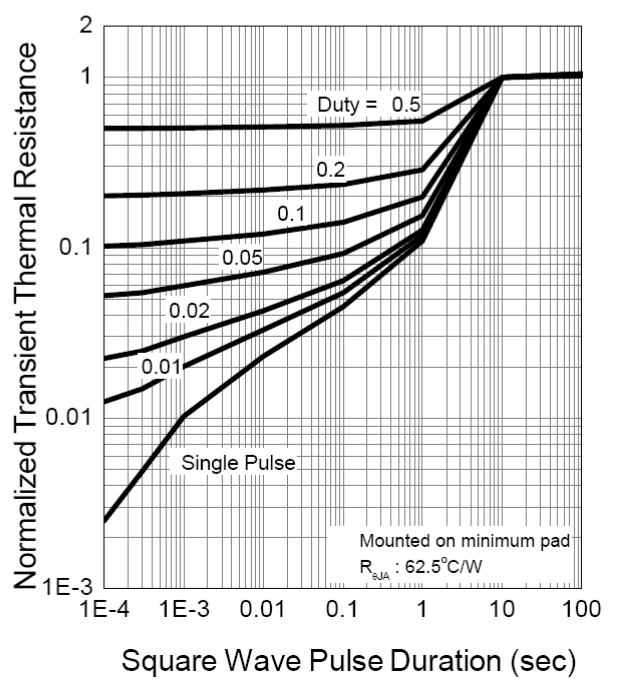

Typical Characteristics (Cont.)

Output Characteristics

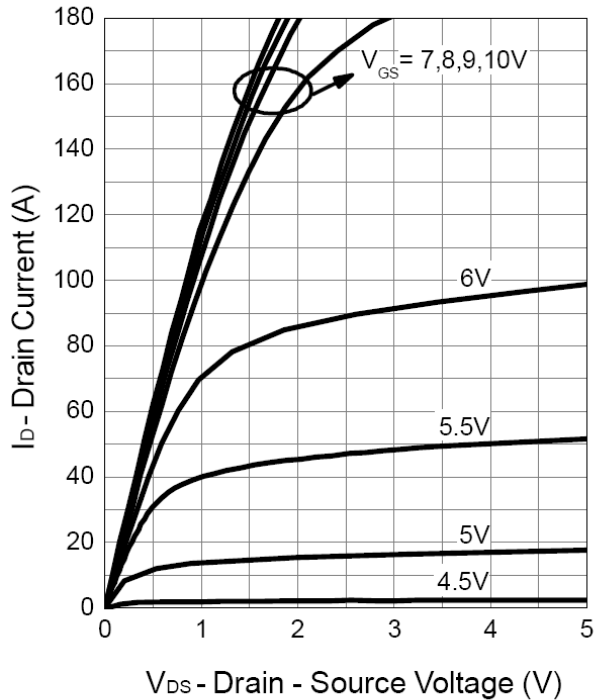

Drain-Source On Resistance

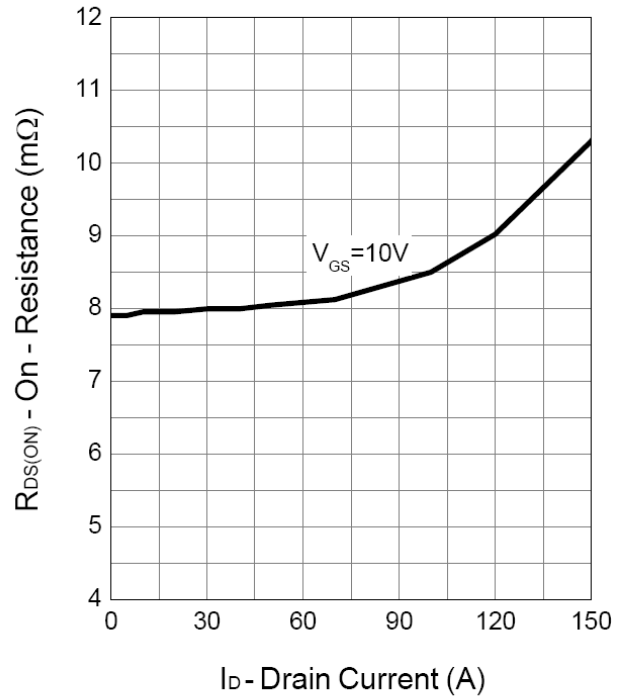

Gate-Source On Resistance

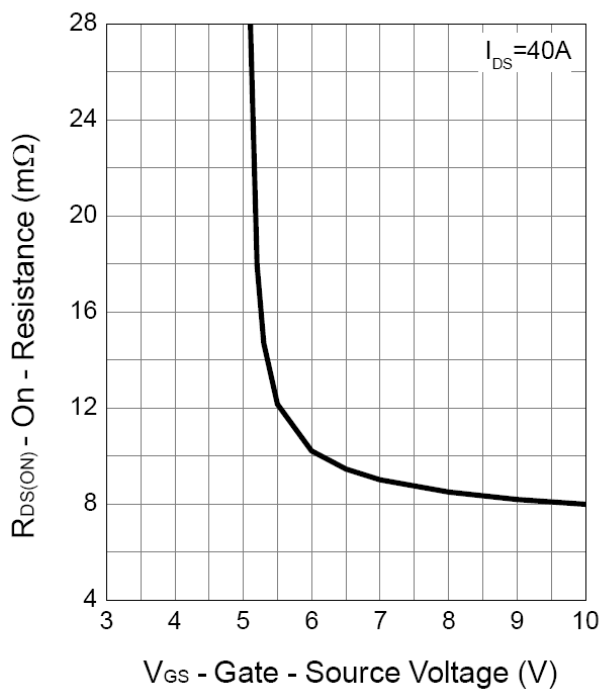

Gate Threshold Voltage

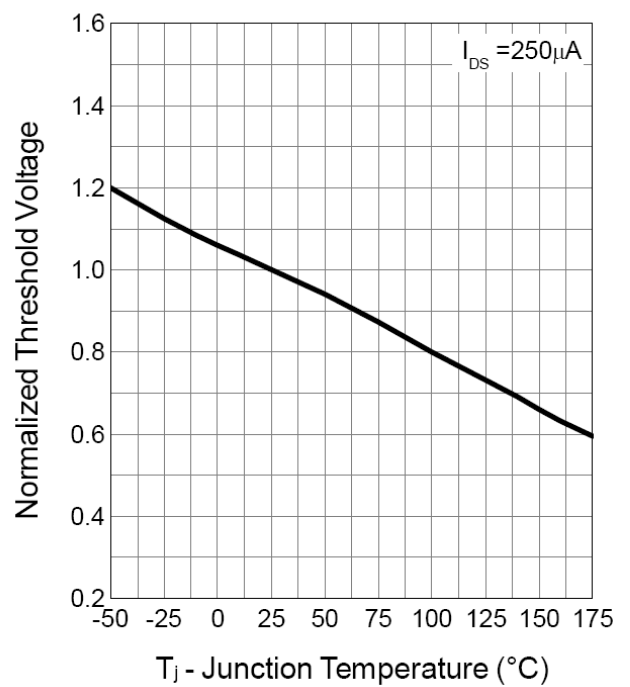

Typical Characteristics (Cont.)

Drain-Source On Resistance

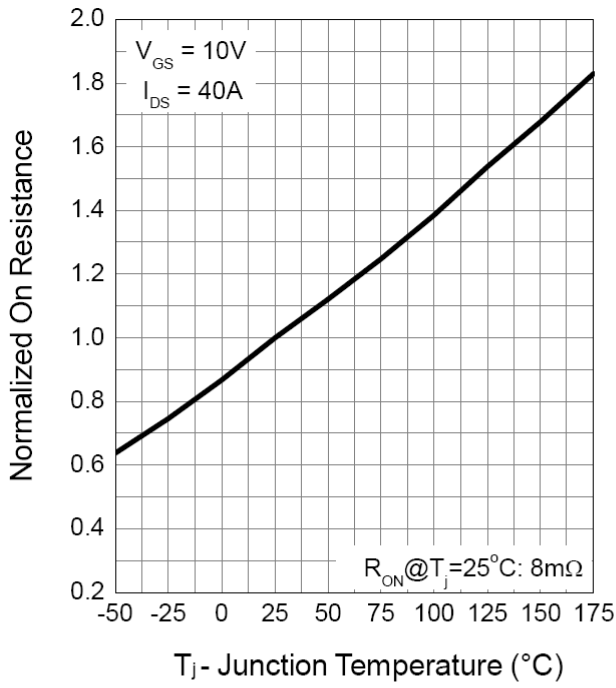

Source-Drain Diode Forward

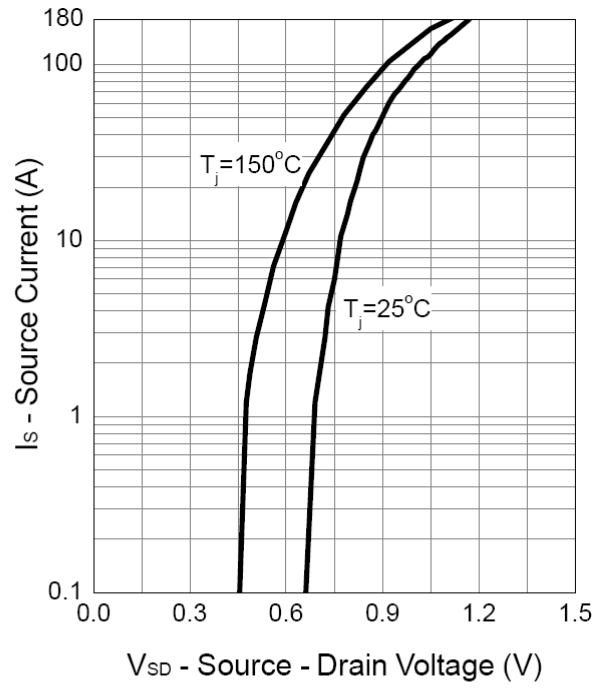

Capacitance

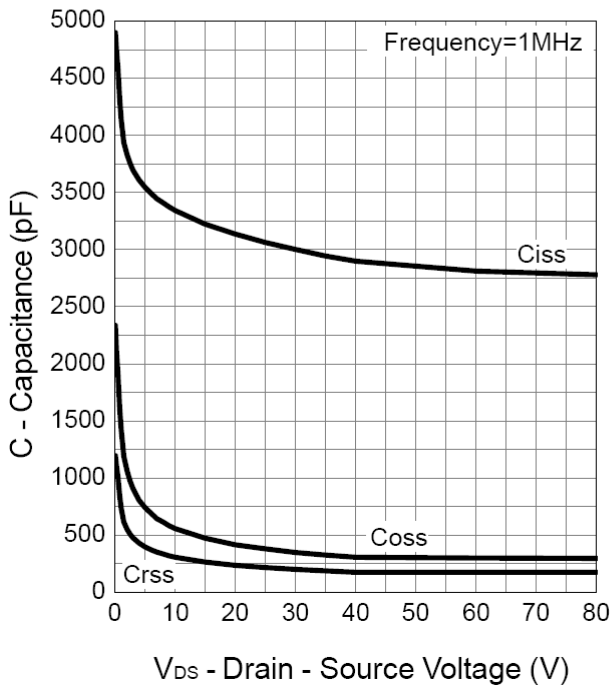

Gate Charge

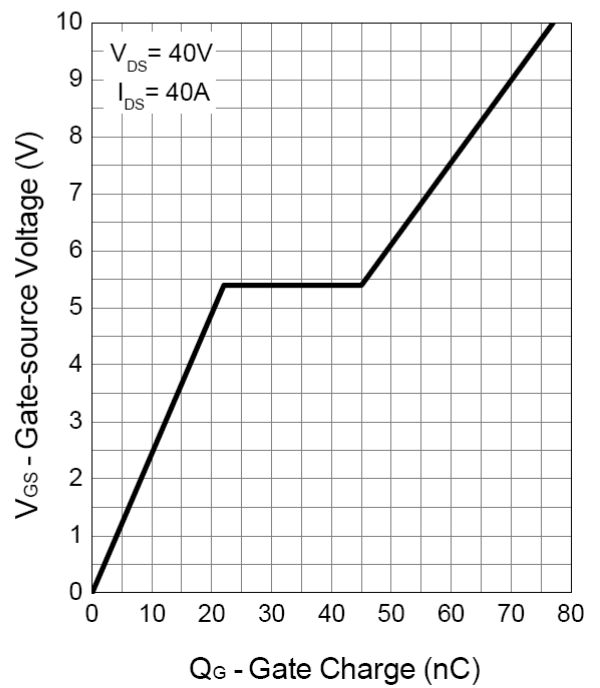

TO-252 Package information

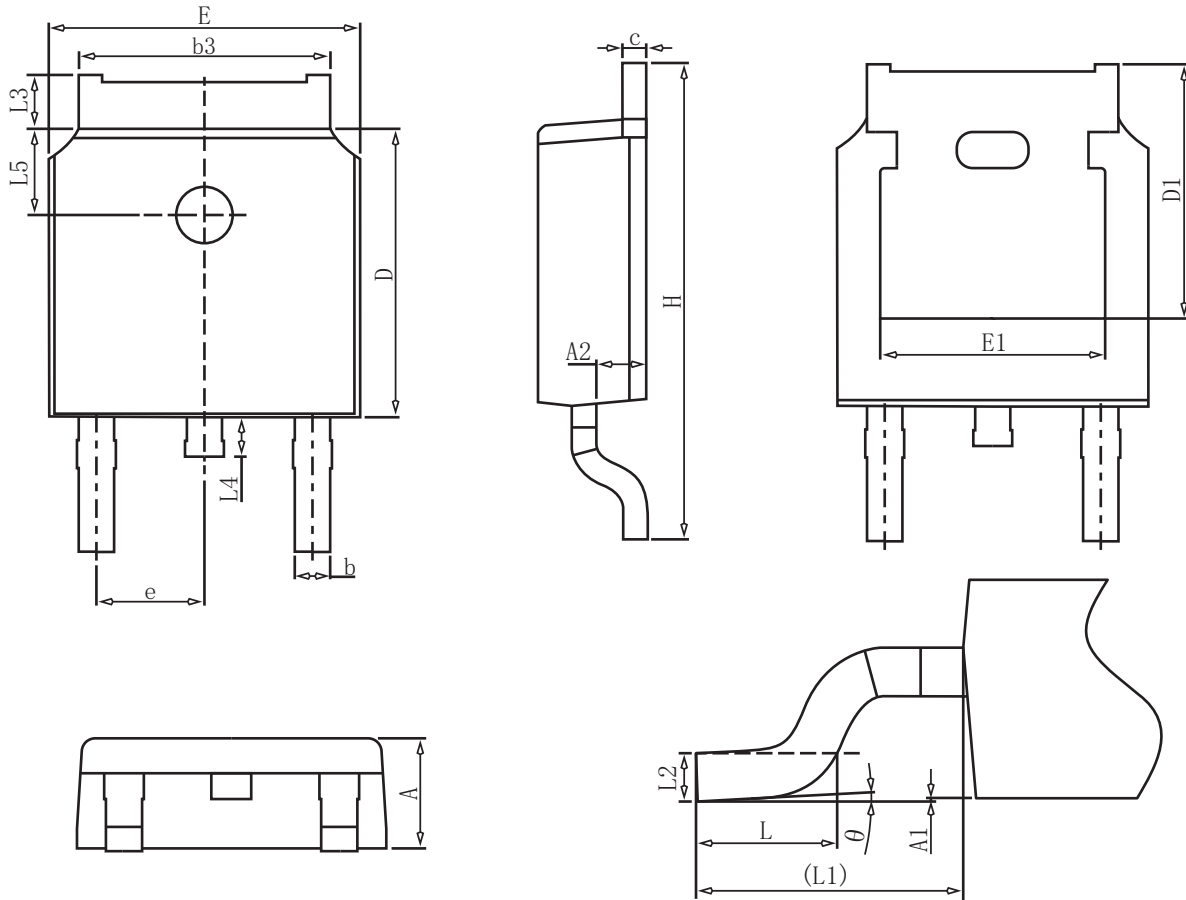

COMMON DIMENSIONS

SYMBOL	mm		
	MIN	NOM	MAX
A	2.20	2.30	2.40
A1	0.00	-	0.20
A2	0.97	1.07	1.17
b	0.68	0.78	0.90
b3	5.20	5.33	5.50
c	0.43	0.53	0.63
D	5.98	6.10	6.22
D1	5.30REF		
E	6.40	6.60	6.80
E1	4.63	-	-
e	2.286BSC		
H	9.40	10.10	10.50
L	1.38	1.50	1.75
L1	2.90REF		
L2	0.51BSC		
L3	0.88	-	1.28
L4	0.50	-	1.00
L5	1.65	1.80	1.95
θ	0°	-	8°

TO-220 Package information

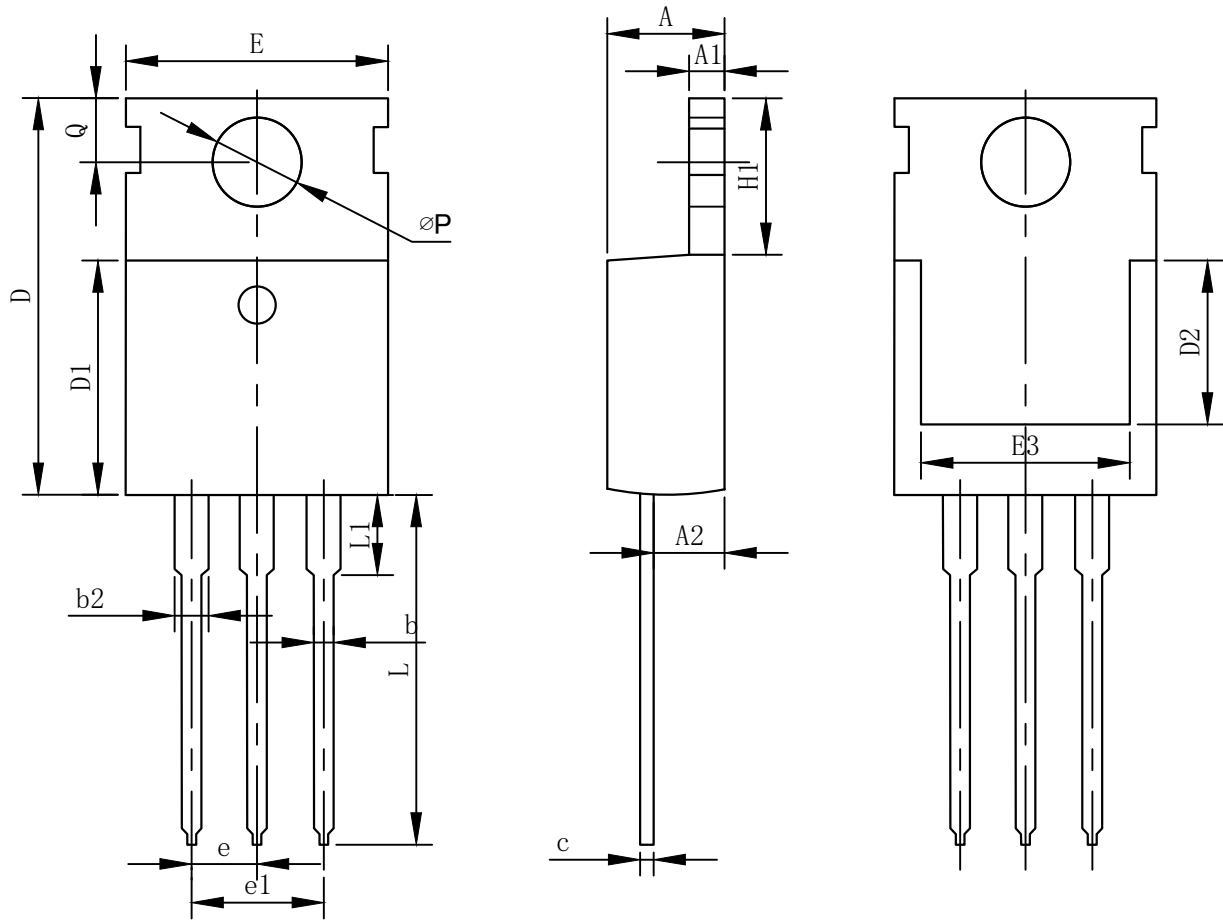

COMMON DIMENSIONS

SYMBOL	mm		
	MIN	NOM	MAX
A	4.37	4.57	4.70
A1	1.25	1.30	1.40
A2	2.20	2.40	2.60
b	0.70	0.80	0.95
b2	1.70	1.27	1.47
c	0.45	0.50	0.60
D	15.10	15.60	16.10
D1	8.80	9.10	9.40
D2	5.50	-	-
E	9.70	10.00	10.30
E3	7.00	-	-
e	2.54BSC		
e1	5.08BSC		
H1	6.25	6.50	6.85
L	12.75	13.50	13.80
L1	-	3.10	3.40
ϕP	3.40	3.60	3.80
Q	2.60	2.80	3.00